



# OptiSlice

## DIRECT INJECT SLICE PRODUCTION

Tomco Systems' OptiSlice produces quality and consistent dry ice blocks without the need of pelletizers, reformers, conveyors or saws. Eliminate cut losses, and reduce power consumption by 80%. Revolutionize the way you do ice.

### Benefits

- No Saws / Reformers Needed
- Reduced Capex & Opex
- 5, 7 or 10 lb Blocks on Demand
- Real-Time Diagnostics
- IoT Web Monitoring
- Compact Footprint
- 1000 lb/hr Capability

## OPTIMAL POWER - OPTIMAL FLEXIBILITY - OPTIMAL SIZE

### OptiSlice

- Production rate: 1,000 lb/hr (up to 1200 lb/hr\*)
- Slice sizes: 10 lb (10 x 10 x 2 in), 7.5 lb (10 x 7.5 x 2 in), 5 lb (10 x 5 x 2 in)
- Direct injection with precision exhaust control for quickest, most efficient injection.
- Improved 100 kW on-demand hydraulic power unit with feedback.
- 80% more energy efficient vs standard hydraulic power unit.
- Over 50% noise reduction
- Standard electrical: 480 VAC, 3 P, 60 Hz
- Multi-function touch screen for easy operation
- Real time hydraulics performance analytics for predictive service intervals
- Remote access for troubleshooting and performance monitoring
- Reduced compact footprint

\* Liquid and exhaust piping are critical to proper operation. Contact your Tomco representative for support.



To see a video of this machine at work, scan the QR code.



# OptiSlice

## DIRECT INJECT SLICE PRODUCTION

|                           |   |
|---------------------------|---|
| Production (lb/hr)        | 1,000                                       |
| Dimensions (WxDxH)        | 74 x 101 x 98 in<br>(1880 x 2566 x 2489 mm) |
| Exit Chute Height         | 34 in (864 mm)                              |
| Decibels                  | < 80 dB                                     |
| Electrical                | 480 VAC, 3Phase, 60 Hz                      |
| Rated Current             | 30 A  |
| Average Power Consumption | 7 kW (9 hp)                                 |

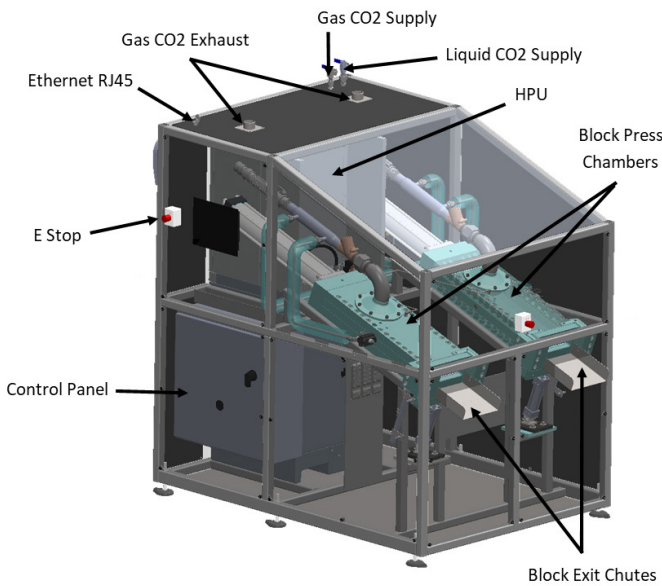
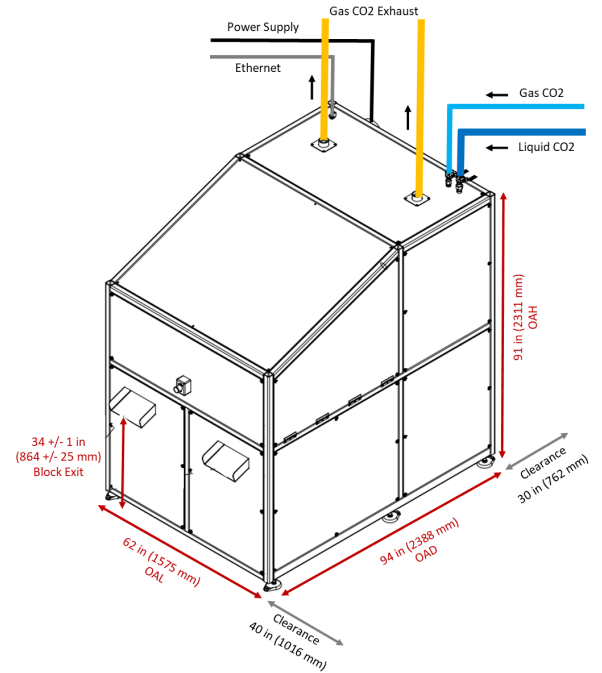

## PIPING

|                                |        |
|--------------------------------|--------|
| Exhaust                        | 2"     |
| CO <sub>2</sub> Vapor          | 1/4"   |
| CO <sub>2</sub> Liquid         | 1" min |
| Max Back Pressure for Recovery | 8 psi  |

\* Liquid and exhaust piping are critical to proper operation. Contact your Tomco representative for support.

Remote monitoring from anywhere on the app.



To see a video of this machine at work, scan the QR code.

